

30XSDI HD PTZ Video Camera User Manual

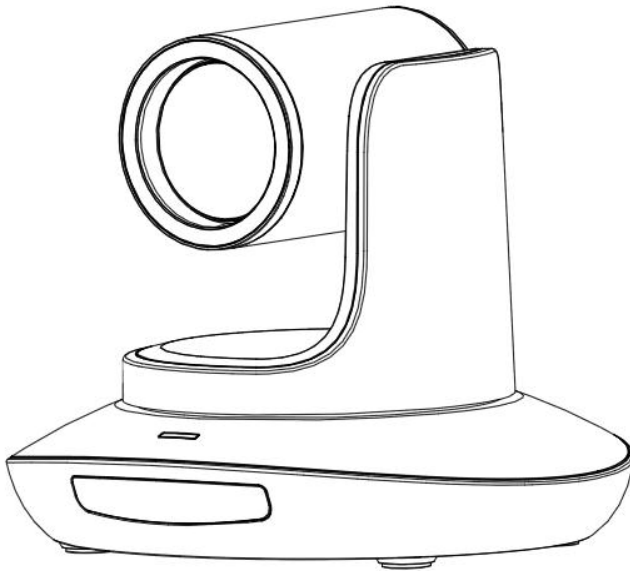

**Version V1.0
(English)**

CONTENTS

SAFETY GUIDES.....	1
PACKING LIST.....	2
QUICK START.....	2
PRODUCT HIGHLIGHTS.....	3
CAMERA SPEC.....	3
CAMERA INTERFACE.....	4
CAMERA DIMENSION.....	4
IR REMOTE CONTROLLER.....	5
VISCA IN(RS232)PORT.....	7
SERIAL PORT CONFIGURATION.....	8
VISCA PROTOCOL.....	8
OSD MENU.....	17

SAFETY GUIDES

1. Before operation, please fully read and follow all instructions in the manual. For your safety, always keep this manual with the camera.
2. The camera power input range is 100-240VAC(50-60Hz), ensure the power supply input within this rate before powering on.
3. The camera power voltage is 12VDC, rated current is 2A. We suggest you use it with the original power supply adapter supplied by the factory.
4. Please keep the power cable, video cable and control cable in a safe place. Protect all cables especially the connectors.
5. Operational environment: 0°C-50°C, humidity less than 90%. To avoid any danger, do not put anything inside the camera, and keep away from the corrosive liquid.
6. Avoid stress, vibration and damp during transportation, storage and installation.
7. Do not detach the camera housing and cover. For any service, please contact authorized technicians.
8. RF cable and control cable should be individually shielded, and cannot be substituted with other cables. Do not direct the camera lens towards strong light, such as the sun or the intensive light.
9. Use a dry and soft cloth to clean the camera housing. Applied with neutral cleaning agent when there is need to clean. To avoid damage on the camera lens, never use strong or abrasive cleaning agents on the camera housing.
10. Do not move the camera by holding the camera head. To avoid mechanical trouble, do not rotate the camera head by hand. NEVER MOVE THE CAMERA MANUALLY WHEN IT IS WORKING.
11. Put the camera on fixed and smooth desk or platform, avoid leaned installation.
12. Power Supply Polarity(Drawing)

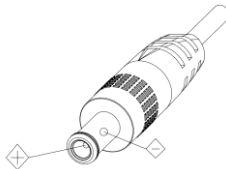

Note: the video quality may be affected by the specific frequencies of electromagnetic field.

ACCESSORIES

Check all bellow items when open the package:

Camera	1
Power Adapter	1
Power Cable	1
RS232 Control Cable	1
Remote Controller	1
User Manual	1
Double-sided Adhesive	1
QC certification	1

QUICK START

1. Check all cable connections before power on.

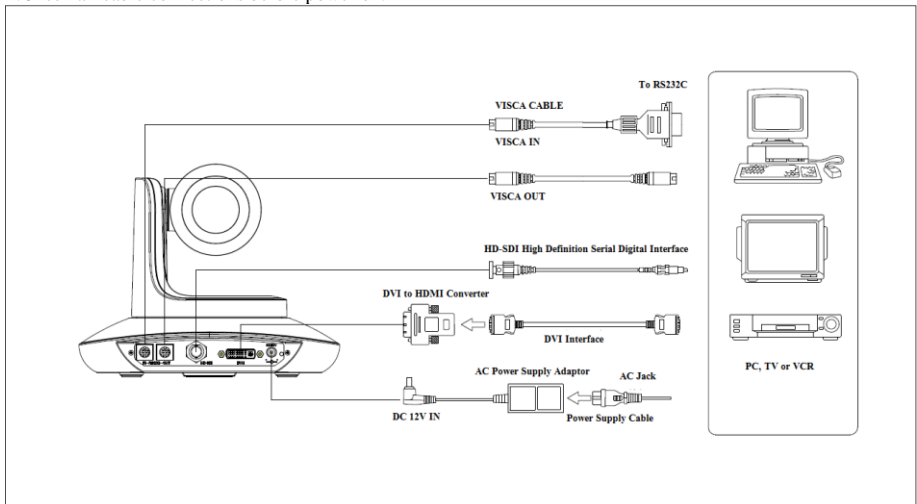

2. Dial Switch Setting (at the bottom of the camera):

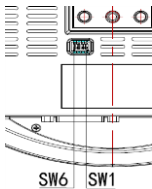

Dial Switch (ARM)			
	SW-1	SW-2	Instruction
1	OFF	OFF	Updating mode
2	ON	OFF	Debugging mode
3	OFF	ON	Undefined
4	ON	ON	Working mode

PRODUCT HIGHLIGHTS

1. Adopted advanced DSP, 1/1.8", 2.3MP sensor and 30x optical lens, provides ultra crystal image quality.
2. Fast switching between different video format.
3. Fast and accurate focus.
4. Support remote firmware update.
5. Daisy chain function: with both Visca in and Visca out port, max 7 cameras can be controlled by RS232 port at Visca protocol.
6. Support RS485 interface
7. Support 128 presets.
8. Be compatible with major video conferencing terminal, customization offered.
9. IR remote controller offered, video format switched by one push.
10. IR transfer/IR pass function: except receiving the camera remote controller signal, the camera can also receive other codec's IR remote control signal, and pass these IR control signal to the codec's IR receiver (via VISCA IN port).
11. Multi language menu: English, Chinese, Russian, Spanish.

CAMERA SPEC

Video Format	1080P59.94/50/29.97/25, 720P59.94/50/29.97/25, 1080I59.94/50,
Video Output	3G-SDI&DVI-I
Sensor	1/1.8 inch, 2.3MP high quality HD CMOS sensor
Lens	F4.5~134.5mm(30X), F1.5~3.4, FOV:59.8°(wide)-3.2°(tele),
Rotation Angle	Pan:±170°; Tilt:-30°~+90°, support up-side down installation
Rotation Speed	Pan: 0.1°/120%; Tilt: 0.1°/80%
Preset	10 via IR remote setting, (128 via COM setting), preset accuracy :0.1°
Control Port	RS232, RS485
Daisy Chain	Supported
Min. Lux	0.2Lux(Day), 0.005Lux(DSS on)
White Balance	Auto/Manual
Focus	Auto/Manual
Iris	Auto/Manual
Shutter	Auto/Manual
Exposure Compensation	Supported
BLC	Supported
2D/3D Noise Reduction	Supported
Input Voltage	DC12V
Dimension	220mm×173mm×117mm
Net Weight	1.55KGS (3.42LBS)

CAMERA INTERFACE

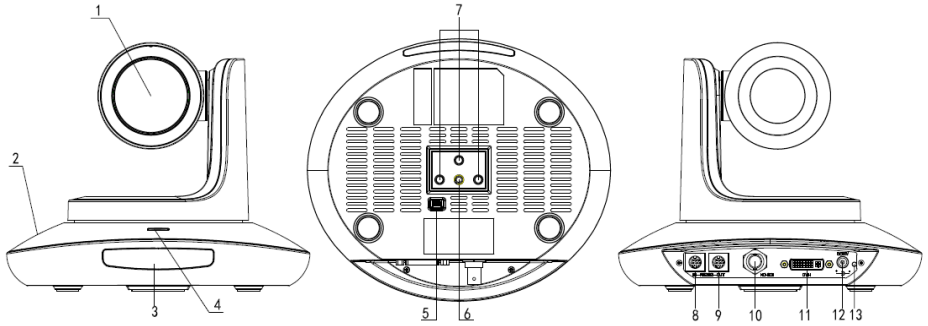

- | | | |
|--------------------------|---------------------------|------------------------|
| 1. Camera Lens | 5. Dial Switch | 9. RS232 control port |
| 2. Camera Base | 6. Tripod Screw Hole | 10. HD-SDI port |
| 3. IR Receiver Panel | 7. Installation Hole | 11. DVI-I port |
| 4. Power Indicator Light | 8. RS232/485 control port | 12. DC12V plug |
| 5. Power Input 12VDC | 14. Power Indicator Light | 13. Power Supply Light |

CAMERA DIMENSION(MM)

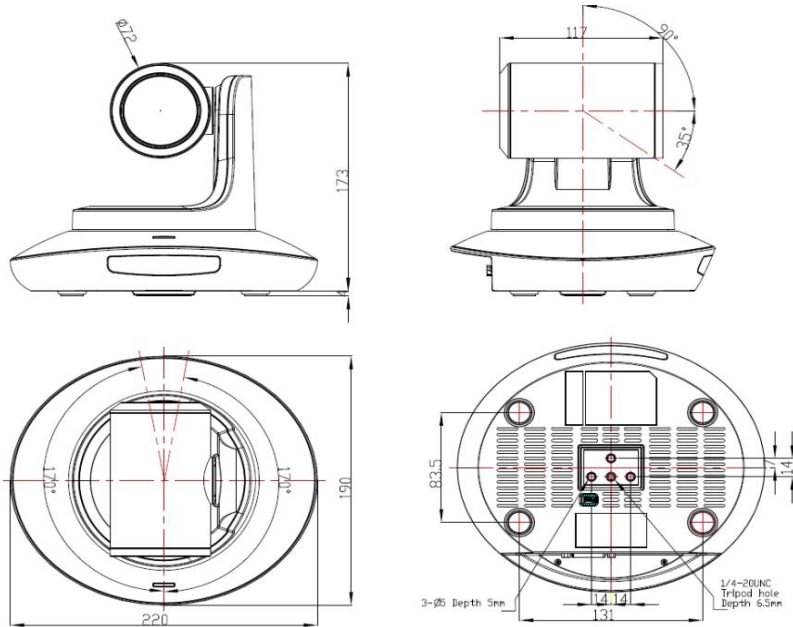

IR REMOTE CONTROLLER

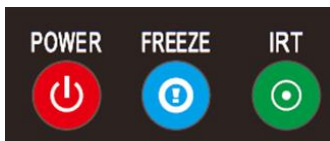

POWER

Under normal working mode, short press POWER key, the camera will enter stand by mode;

Press it again, the camera will do self-configuration, then go back to HOME position.

It will go to preset position if power on model has been set before.

FREEZE (Not Supported)

Short press FREEZE key to freeze/ unfreeze the image.

IRT(IR Transfer/IR Pass)

Open or close the IR pass function. Once press the IRT key, the camera will receive and pass the IR remote control signal to the codec/terminal(via VISCA IN port).

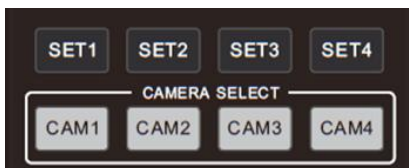

SET 1~SET4 ADDRESS SETTING

Long press for 3seconds until the key light ON, to set camera address.

CAM1~CAM4 (CAMERA SELECTING)

Short press to select the relative camera.

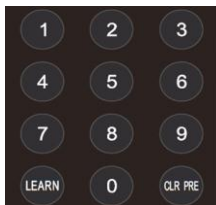

NUMBER KEY(1-9)

Set preset: long press(3 seconds) the number key to set preset.

Run preset: Short press the number key to run preset.

CLR PRE(CLEAR PRESET)

CLR PRE+ number key: to clear the relative preset.

Long press to clear all preset.

LEARN

Reserved, not available now.



FOCUS KEY(ON THE LEFT)

Manual focus, only valid under manual focus model.

ZOOM KEY(ON THE RIGHT SIDE)

Set the zoom rate

NAVIGATE KEY: UP/DOWN/LEFT/RIGHT

Under working mode, use navigate key to set the pan tilt, and select menu when enter OSD.

OK /HOME KEY

Under working mode, short press OK to make the camera go back to HOME position; and confirm the selection when enter OSD.

AF: Auto Focus

MF: Manual Focus

RESET: Reset camera

MENU: Enter OSD menu

LEARN+LIMIT L key: Set the pan tilt left limit position.

LEARN+LIMIT R key: Set the pan tilt right limit position.

LEARN+LMT CLR key: Clear the limit position.

BLC OFF/ BLC ON: Not Available

BRIGHT-/BRIGHT+: Set image brightness, only valid under bright

priority exposure mode.

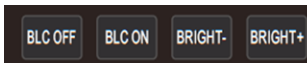
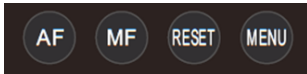

Video Format Keys:

Long press 3 seconds to select different video format output.

Note: In special enviroment, due to heavy infrared interfere,(for instance: the camera is put on the screen with infrared touch function or there is strong light iodine-tungsten lamp), the camera IR receival maybe effected to execute wrong command. In this case, turn off IR receival by set 3-4 dial switch on the bottom to be OFF if users don't need IR remote controller.



VISCA IN (RS232 PORT)

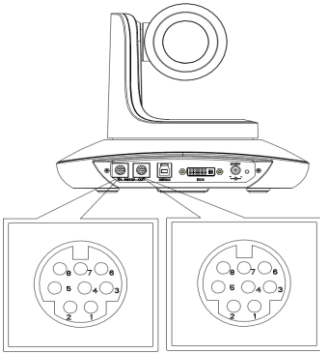

No.	Function
1	DTR
2	DSR
3	TXD
4	GND
5	RXD
6	A
7	IR OUT
8	B

VISCA IN & RS485 Connection

Camera VISCA IN		RS485
1	DTR	
2	DSR	
3	TXD	
4	GND	GND
5	RXD	
6	A(+)	A(+)
7	IR OUT	
8	B(-)	B(-)

VISCA IN & Mini DIN Connection

Camera VISCA IN		Mini DIN	
1	DTR	1	DSR
2	DSR	2	DTR
3	TXD	5	RXD
4	GND	4	GND
5	RXD	3	TXD
6	A(+)	6	GND
7	IR OUT	7	NC
8	B(-)	8	NC

VISCA IN & DB9 Connection

Camera VISCA IN		Windows DB-9	
1	DTR	6	DSR
2	DSR	4	DTR
3	TXD	2	RXD
4	GND	5	GND
5	RXD	3	TXD
6	A(+)		
7	IR OUT		
8	B(-)		

VISCA Network Construction:

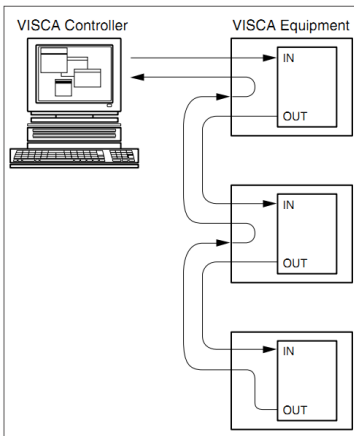

SERIAL PORT CONFIGURATION

Parameter	Value	Parameter	Value
Baud rate	2400/4800/9600/115200	Stop Bit	1bit
Start Bit	1 bit	Check Bit	None
Date Bit	8 bit		

VISCA PROTOCOL

Part1 Camera Return Command

Ack/Completion Message		
	Command Packet	Note
ACK	z0 41 FF	Returned when the command is accepted.
Completion	z0 51 FF	Returned when the command has been executed.

z = camera address+8

Error Messages		
	Command Packet	Note
Syntax Error	z0 60 02 FF	Returned when the command format is different or when a command with illegal command parameters is accepted.
Command Not Executable	z0 61 41 FF	Returned when a command cannot be executed due to current conditions. For example, when commands controlling the focus manually are received during auto focus.

Part 2 Camera Control Command

Command	Function	Command Packet	Note
AddressSet	Broadcast	88 30 01 FF	Address setting
IF_Clear	Broadcast	88 01 00 01 FF	I/F Clear
CommandCancel		8x 21 FF	
CAM_Power	On	8x 01 04 00 02 FF	Power ON/OFF
	Off	8x 01 04 00 03 FF	
CAM_Zoom	Stop	8x 01 04 07 00 FF	p = 0(low)~7(high)
	Tele(Standard)	8x 01 04 07 02 FF	
	Wide(Standard)	8x 01 04 07 03 FF	
	Tele(Variable)	8x 01 04 07 2p FF	
	Wide(Variable)	8x 01 04 07 3p FF	
	Direct	8x 01 04 47 0p 0q 0r 0s FF	pqrs: Zoom Position (0(wide) ~0x4000(tele))
CAM_DZoom	ON	8x 01 04 06 02 FF	
	OFF	8x 01 04 06 03 FF	
CAM_Focus	Stop	8x 01 04 08 00 FF	

Command	Function	Command Packet	Note
	Far(Standard)	8x 01 04 08 02 FF	
	Near(Standard)	8x 01 04 08 03 FF	
	Direct	8x 01 04 48 0p 0q 0r 0s FF	pqrs: Focus Position
	One Push AF	8x 01 04 18 01 FF	
CAM_AFSensitivity (new)	AF sensitivity	8x 01 04 68 0p FF	p: AF sensitivity 1:High 2:Normal 3:Low
CAM_ZoomFocus	Direct	8x 01 04 47 0p 0q 0r 0s 0t 0u 0v 0w FF	pqrs: Zoom Position (0(wide)~ 0x4000(tele)) tuvw: Focus Position
CAM_WB	Auto	8x 01 04 35 00 FF	
	Indoor	8x 01 04 35 01 FF	
	Outdoor	8x 01 04 35 02 FF	
	OnePush	8x 01 04 35 03 FF	
	ATW	8x 01 04 35 04 FF	
	Manual	8x 01 04 35 05 FF	
CAM_RGain	Reset	8x 01 04 03 00 FF	Manual Control of R Gain
	Up	8x 01 04 03 02 FF	
	Down	8x 01 04 03 03 FF	
	Direct	8x 01 04 43 00 00 0p 0q FF	pq: R Gain (0~0xFF)
CAM_Bgain	Reset	8x 01 04 04 00 FF	Manual Control of B Gain
	Up	8x 01 04 04 02 FF	
	Down	8x 01 04 04 03 FF	
	Direct	8x 01 04 44 00 00 0p 0q FF	pq: B Gain (0~0xFF)
CAM_AE	Full Auto	8x 01 04 39 00 FF	Automatic Exposure mode
	Manual	8x 01 04 39 03 FF	Manual Control mode
	Bright	8x 01 04 39 0D FF	Bright mode(Manual control)
CAM_Shutter	Reset	8x 01 04 0A 00 FF	Shutter Setting
	Up	8x 01 04 0A 02 FF	
	Down	8x 01 04 0A 03 FF	
	Direct	8x 01 04 4A 00 00 0p 0q FF	pq: Shutter Position (0~0x15)
CAM_Iris	Reset	8x 01 04 0B 00 FF	Iris Setting
	Up	8x 01 04 0B 02 FF	
	Down	8x 01 04 0B 03 FF	
	Direct	8x 01 04 4B 00 00 0p 0q FF	pq: Iris Position (0~ 0x11)
CAM_Gain	Reset	8x 01 04 0C 00 FF	Gain Setting

Command	Function	Command Packet	Note
	Up	8x 01 04 0C 02 FF	
	Down	8x 01 04 0C 03 FF	
	Direct	8x 01 04 0C 00 00 0p 0q FF	
CAM_Bright	Reset	8x 01 04 0D 00 FF	Bright Setting
	Up	8x 01 04 0D 02 FF	
	Down	8x 01 04 0D 03 FF	
	Direct	8x 01 04 4D 00 00 0p 0q FF	pq: Bright I Positon ()
CAM_WDR	On	8x 01 04 3D 02 FF	Exposure Compensation ON/OFF
	Off	8x 01 04 3D 03 FF	
	Direct	8x 01 04 2D pq FF	pq: ExpComp Position (0~0x6E)
CAM_BackLight(BLC)	On	8x 01 04 33 02 FF	BackLight On
	Off	8x 01 04 33 03 FF	BackLight Off
CAM_Sharpness	Reset	8x 01 04 02 00 FF	Aperture Control
	Up	8x 01 04 02 02 FF	
	Down	8x 01 04 02 03 FF	
	Direct	8x 01 04 42 00 00 0p 0q FF	pq: Aperture Gain (0~0x0F)
CAM_Memory(preset)	Reset	8x 01 04 3F 00 0p FF	p: Preset Number(=0 to 127) Corresponds to 0 to 9 on the Remote Commander
	Set	8x 01 04 3F 01 0p FF	
	Recall	8x 01 04 3F 02 0p FF	
CAM_LR_Reverse	On	8x 01 04 61 02 FF	Image Flip Horizontal ON/OFF
	Off	8x 01 04 61 03 FF	
CAM_PictureFlip	On	8x 01 04 66 02 FF	Image Flip Vertical ON/OFF
	Off	8x 01 04 66 03 FF	
CAM_RS485Ctl(new)	On	8x 01 06 A5 02 FF	
	Off	8x 01 06 A5 03 FF	
CAM_VGActl(new)	VGA	8x 01 06 B6 02 FF	
	YPbPr	8x 01 06 B6 03 FF	
CAM_TransferCtl(new)	On	8x 01 06 1A 02 FF	Receive IR(remote commander) CODE from VISCA communication ON/OFF
	Off	8x 01 06 1A 03 FF	
CAM_LanguageSet (new)	Language	8x 01 06 D3 0p FF	P:language: 1:English 2:Chinese 3:Russian 4:Spanish
CAM_Contrast(new)	Contrast	8x 01 04 A2 00 00 0p 0q FF	pq :contrast level 0x00~0xff
CAM_Saturation(new)	Saturation	8x 01 04 A1 00 00 0p 0q FF	pq :saturation level 0x00~0xff

Command	Function	Command Packet	Note
CAM_PWR_ACT(new)	Preset 0	8x 01 06 A8 00 FF	Auto run to preset setted after power on
	Preset 1	8x 01 06 A8 01 FF	
	Off	8x 01 06 A8 02 FF	
CAM_SpeedByZoom (new)	On	8x 01 06 A0 02 FF	
	Off	8x 01 06 A0 03 FF	
CAM_PTSpeed(new)	PT Speed	8x 01 04 C1 00 00 0p 0q FF	pp :PT speed 0x05~0x18
CAM_ZoomSpeed(new) (remote)	Zoom Speed	8x 01 04 D1 00 00 0p 0q FF	pp :Zoom speed 0x01~0x07
CAM_TrackMode(new)	Fluent	8x 01 06 C5 02 FF	
	Precise	8x 01 06 C5 03 FF	
CAM_MenuMirror(new)	Normal	8x 01 06 C8 00 FF	
	Mirror	8x 01 06 C8 01 FF	
CAM_SYSReset(new)	Reset	8x 01 06 D2 01 FF	
CAM_CAMReset(new)	Reset	8x 01 06 D2 02 FF	
CAM_ALLReset(new)	Reset	8x 01 06 D2 03 FF	
CAM_ZoomDisplay (new)	On	8x 01 06 C2 02 FF	
	Off	8x 01 06 C2 03 FF	
CAM_IRAddress(new)	IR address	8x 01 06 D8 0p FF	p:IR address 1~4
CAM_Gamma(new)	Gamma set	81 01 04 5B 0p FF	P:Gamma NO.
CAM_MountMode	UP	8x 01 04 A4 02 FF	Mount Up
	Down	8x 01 04 A4 03 FF	Mount Down
CAM_ColorGain	Direct	8x 01 04 49 00 00 00 0p FF	(0~0x0E)
CAM_2D Noise Reduction	Direct	8x 01 04 53 0p FF	(0~0x05)
CAM_3D Noise Reduction	Direct	8x 01 04 54 0p FF	(0~0x03)
FLICK	50HZ	81 01 04 23 01 FF	
	60HZ	81 01 04 23 02 FF	
	OFF	81 01 04 23 00 FF	
Freeze	Freeze On	81 01 04 62 02 FF	Freeze On Immediately
	Freeze Off	81 01 04 62 03 FF	Freeze Off Immediately
	Preset Freeze On	81 01 04 62 22 FF	Freeze On When Running Preset
	Preset Freeze Off	81 01 04 62 23 FF	Freeze Off When Running Preset
VideoSystem Set		8x 01 06 35 00 pp FF	pp: 0~9 Video format 0:1080P59.94 5:1080P25 1:1080P50 6:720P59.94 2:1080I59.94 7:720P50 3:1080I50 8:720P29.97

Command	Function	Command Packet	Note
			4:1080P29.97 9:720P25
CAM_IDWrite		8x 01 04 22 0p 0q 0r 0s FF	pqrs: Camera ID (=0000 to FFFF)
SYS_Menu	Menu On	8x 01 06 06 02 FF	Turn on the menu
	Menu Off	8x 01 06 06 03 FF	Turn off the menu
	Menu Back	8x 01 06 06 10 FF	Menu step back
	Menu Ok	8x 01 7E 01 02 00 01 FF	Menu ok
IR_Receive	On	8x 01 06 08 02 FF	IR(remote commander)receive ON/OFF
	Off	8x 01 06 08 03 FF	
	On/Off	8x 01 06 08 10 FF	
Pan_tiltDrive	Up	8x 01 06 01 VV WW 03 01 FF	VV: Pan speed 0x01 (low speed) to 0x18 (high speed) WW: Tilt speed 0x01 (low speed) to 0x14 (high speed) YYYY: Pan Position(TBD) ZZZZ: Tilt Position(TBD)
	Down	8x 01 06 01 VV WW 03 02 FF	
	Left	8x 01 06 01 VV WW 01 03 FF	
	Right	8x 01 06 01 VV WW 02 03 FF	
	Upleft	8x 01 06 01 VV WW 01 01 FF	
	Upright	8x 01 06 01 VV WW 02 01 FF	
	DownLeft	8x 01 06 01 VV WW 01 02 FF	
	DownRight	8x 01 06 01 VV WW 02 02 FF	
	Stop	8x 01 06 01 VV WW 03 03 FF	
	AbsolutePosition	8x 01 06 02 VV WW 0Y 0Y 0Y 0Y 0Z 0Z 0Z 0Z FF	
	RelativePosition	8x 01 06 03 VV WW 0Y 0Y 0Y 0Y 0Z 0Z 0Z 0Z FF	
	Home	8x 01 06 04 FF	
	Reset	8x 01 06 05 FF	
Pan-tiltLimitSet	Set	8x 01 06 07 00 0W 0Y 0Y 0Y 0Y 0Z 0Z 0Z 0Z FF	W:1 UpRight 0:DownLeft YYYY: Pan Limit Position(TBD) ZZZZ: Tilt Limit Position(TBD)
	Clear	8x 01 06 07 01 0W 07 0F 0F 0F 07 0F 0F 0F FF	

PART 3 INQUIRY COMMAND

Command	Command Packet	Return Packet	Note
CAM_PowerInq	8x 09 04 00 FF	y0 50 02 FF	On
		y0 50 03 FF	Off(Standby)
CAM_ZoomPosInq	8x 09 04 47 FF	y0 50 0p 0q 0r 0s FF	pqrs: Zoom Position
CAM_FocusModelInq	8x 09 04 38 FF	y0 50 02 FF	Auto Focus
		y0 50 03 FF	Manual Focus
CAM_FocusPosInq	8x 09 04 48 FF	y0 50 0p 0q 0r 0s FF	pqrs: Focus Position
CAM_WBModelInq	8x 09 04 35 FF	y0 50 00 FF	Auto
		y0 50 01 FF	Indoor mode

		y0 50 02 FF	Outdoor mode
		y0 50 03 FF	OnePush mode
		y0 50 04 FF	ATW
		y0 50 05 FF	Manual
CAM_RGainInq	8x 09 04 43 FF	y0 50 00 00 0p 0q FF	pp: R Gain
CAM_BGainInq	8x 09 04 44 FF	y0 50 00 00 0p 0q FF	pp: B Gain
CAM_AEModeInq	8x 09 04 39 FF	y0 50 00 FF	Full Auto
		y0 50 03 FF	Manual
		y0 50 0A FF	Shutter priority
		y0 50 0B FF	Iris priority
		y0 50 0D FF	Bright
CAM_ShutterPosInq	8x 09 04 4A FF	y0 50 00 00 0p 0q FF	pp: Shutter Position
CAM_IrisPosInq	8x 09 04 4B FF	y0 50 00 00 0p 0q FF	pp: Iris Position
CAM_GainPosInq	8x 09 04 4C FF	y0 50 00 00 0p 0q FF	pp: Gain Position
CAM_BrightPosInq	8x 09 04 4D FF	y0 50 00 00 0p 0q FF	pp: Bright Position
CAM_ExpCompModelInq	8x 09 04 3E FF	y0 50 02 FF	On
		y0 50 03 FF	Off
CAM_ExpCompPosInq	8x 09 04 4E FF	y0 50 00 00 0p 0q FF	pp: ExpComp Position
CAM_ApertureInq	8x 09 04 42 FF	y0 50 00 00 0p 0q FF	pp: Aperture Gain
CAM_MemoryInq	8x 09 04 3F FF	y0 50pp FF	pp: Memory number last operated.
SYS_MenuModelInq	8x 09 06 06 FF	y0 50 02 FF	On
		y0 50 03 FF	Off
CAM_LR_ReverseInq	8x 09 04 61 FF	y0 50 02 FF	On
		y0 50 03 FF	Off
CAM_PictureFlipInq	8x 09 04 66 FF	y0 50 02 FF	On
		y0 50 03 FF	Off
CAM_IDInq	8x 09 04 22 FF	y0 50 0p 0q 0r 0s FF	pprs: Camera ID
CAM_VersionInq	8x 09 00 02 FF	y0 50 ab cd mn pq rs tu vw FF	
VideoSystemInq	8x 09 06 23 FF	y0 50 pp FF	pp: 0~9 Video format 0:1080P59.94 5:1080P25 1:1080P50 6:720P59.94 2:1080I59.94 7:720P50 3:1080I50 8:720P29.97 4:1080P29.97 9:720P25
IR_Transfer	8x 09 06 1A FF	y0 50 02 FF	On
		y0 50 03 FF	Off
IR_Receive	8x 09 06 08 FF	y0 50 02 FF	On
		y0 50 03 FF	Off
IR_ReceiveReturn		y0 07 7D 01 04 00 FF	Power ON/OFF
		y0 07 7D 01 04 07 FF	Zoom tele/wide
		y0 07 7D 01 04 38	AF On/Off

		FF	
		y0 07 7D 01 04 33 FF	CAM_Backlight
		y0 07 7D 01 04 3F FF	CAM_Memory
		y0 07 7D 01 06 01 FF	Pan_tiltDrive
Pan-tiltMaxSpeedInq	8x 09 06 11 FF	y0 50 ww zz FF	ww: PanMaxSpeed zz: Tilt Max Speed
Pan-tiltPosInq	8x 09 06 12 FF	y0 50 0w 0w 0w 0w 0z 0z 0z 0z FF	www: PanPosition zzzz: Tilt Position

Note: **【x】** means the camera address ; **【y】** = **【x + 8】** .

VISCA PAN TILT ABSOLUTE POSITION VALUE

Pan Angle	VISCA Value	Tilt Angle	VISCA Value
-170	0xF670	-30	0xFE50
-135	0xF868	0	0x0000
-90	0xFAF0	30	0x01B0
-45	0xFD78	60	0x0360
0	0x0000	90	0x510
45	0x0288		
90	0x0510		
135	0x0798		
170	0x0990		

VISCA PAN TILT SPEED VALUE

Pan(Degree/Second)		tilt(Degree/Second)	
0	0.5	0	0.5
1	1	1	1
2	1.5	2	1.5
3	2.2	3	2.2
4	2.4	4	3.6
5	2.6	5	4.7
6	2.8	6	6
7	3.0	7	8
8	3.2	8	10
9	3.4	9	12
10	3.8	10	15
11	4.5	11	18
12	6	12	23
13	9	13	30
14	15	14	39
15	19	15	48
16	25	16	59
17	32	17	69
18	38	18	80
19	45		
20	58		
21	75		
22	88		
23	105		
24	120		

VISCA EXPOSURE VALUE

Shutter speed		60/30mode	50/25mode	Iris	0D	F1.55
	21	1/10000	1/10000		0C	F2.22
	20	1/6000	1/6000		0B	F2.51
	19	1/4000	1/3500		0A	F2.68
	18	1/3000	1/2500		09	F2.8
	17	1/2000	1/1750		08	F2.89
	16	1/1500	1/1250		07	F2.96
	15	1/1000	1/1000		06	F3.03
	14	1/725	1/600		05	F 3.08
	13	1/500	1/425		04	F3.13
	12	1/350	1/300		03	F3.18
	11	1/250	1/215		02	F3.22
	10	1/180	1/150		01	F3.4
	9	1/125	1/120		00	CLOSE
	8	1/100	1/100			
	7	1/90	1/75			
	6	1/60	1/50			
	5	1/30	1/25			
	4	1/15	1/12			
	3	1/8	1/6			
	2	1/4	1/3			
1	1/2	1/2				
0	1/1	1/1				
Gain	0	0dB		Gain	8	16dB
	1	2dB			9	18dB
	2	4dB			10	20dB
	3	6dB			11	22dB
	4	8dB			12	24dB
	5	10dB			13	26dB
	6	12dB			14	28dB
	7	14dB				

OSD MENU

1.Under working mode, press the MENU key on the IR remote controller, to enter the OSD menu as below:

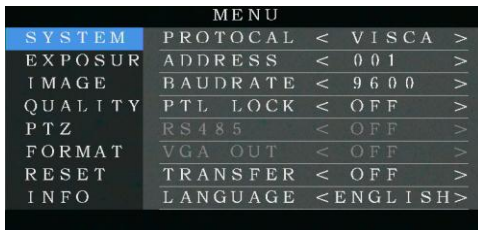

2.After enter the main menu, use the navigate UP/DOWN key to select the main menu. Once been selected, the main menu will change to blue background, and the right side will show all sub menu options .

3.Press the navigate RIGHT key to enter sub menu; use UP/DONW key to select the sub menu;use LEFT/RIGHT key to select parameter.

4. Press the MENU key again to return to previous menu. Press the MENU key continuously to exit the OSD menu. Before exiting, will show up a window to select whether need to save all settings(useLEFT/RIGHT key to set). As bellow:

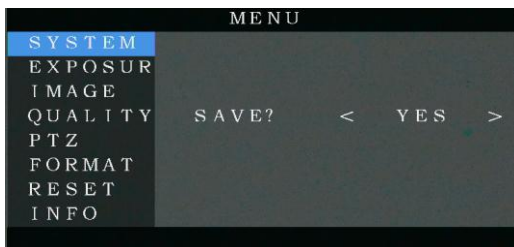

5.OSD Menu Setting List

SYSTEM	PROTOCOL	VISCA
	ADDRESS	VISCA:1~7 PELCO-P/D:1~255
	BAUD RATE	2400,4800,9600,115200
	PTL LOCK	Protocol lock: once set, above protocol setting will be locked, to avoid changes
	RS485	RS485 ON/OFF
	VGA OUT	VGA output can be YPbPr or VGA output (customized)
	TRANSFER	IR Transfer/IR Pass function
	LANGUAGE	Chinese, English, Spanish, Russian

EXPOSURE	EXPOSURE MODE	AUTO、MANUAL、 BRIGHT, SHUTTER, IRIS
	SHUTTER	Shutter speed:1/8~1/10000, only valid under manual mode
	IRIS	Iris setting:CLOSE~F1.5, only valid under manual mode
	GAIN	Gain setting:0dB~28dB , only valid under manual mode

	BRIGHT	Bright setting:0~15, only valid under bright priority mode.
	EC MODE	Exposure compensation ON/FF
	EC POSI	Set exposure compensation lever
	BLC	Back light compensation ON/FF

IMAGE	WB MODE	White Balance:AUTO、INDOOR、OUTDOOR、MANUAL、OUTAUTO、ONEPUSH, ATW
	R GAIN	Red gain level: 0~255, only valid under manual white balance mode.
	B GAIN	Blue gain level:0~255 , only valid under manual white balance mode.
	COLOR G	Color gain setting: 0~14 (Not Available)
	FLICK	Anti-Flicker setting:50/60HZ, to reduce the video flicker
	FREEZE	Image freeze when run preset(customization)
	DZOOM	Turn on/off digital zoom
	FOCUS	Select focus mode

QUALITY	2D NR	2D noise reduction:0~5, the bigger value, the less noise on image, the lower resolution
	3D NR	3D noise reduction:0~3, the bigger value, the less motion noise on image.
	SHARPNESS	Sharpness setting: 0~6, the higher value, the higher resolution.
	CONTRAST	Set contrast level
	SATURATION	Set saturation.
	TRACK MODE	Absolute position mode selection: PRECISE/FLUENT
	GAMMAR	Select gammar level

PTZ	PWR ACT	Set power on action: OFF, PRE1, PRE2
	SPEEDBYZ	Speed by zoom: proportional speed, the bigger zoom, the slower speed.
	MOUNT M	Mount mode: up, down
	FLIPHOR	Flip horizontal
	FLIP VER	Flip vertical
	PT SPD	Set pan tilt speed
	ZOOM SPD	Set zoom speed
	MENU MIR	Turn on/off left/menu mirror function.

VIDEO FORMAT	1080P59.94	1080P25	Once selected, press OK key to confirm.
	1080P50	720P59.94	
	1080I59.94	720P50	
	1080I50	720P29.97	
	1080P29.97	720P25	

RESET	SYS RESET	System reset
	CAM RESET	Camera reset
	PT RESET	Pan tilt reset
	ALL RESET	All reset
	ZOOM DISPLAY	Select if zoom display

MESSAGE	IR ADDR	Camera IR control address
	FOCUS	Focus mode
	CLIENT	Client protocol, can't be changed
	MODEL NO.	Model number
	ARM VER	ARM version
	FPGA VER	FPGA version
	CAM VER	Camera version
	RELEASE	Software release date